

Sealed SKF Explorer spherical roller bearings

Optimum protection against contaminants, downtime and high maintenance costs



One choice. Every advantage.

Sealed vs. open bearing



- Increase availability (KPI)
- Lower total cost of bearing purchase
- Operational until planned maintenance stop
- Reduce risk of failure
- Have option to downsize



- Minimize purchase cost
- Remove environmental footprint
- Minimize grease destruction cost



- Reduce maintenance needed
- Reduce injury risk
- Enable easier maintenance planning



Good for productivity, maintenance and the environment

Ideal for conveyors operating in tough environments, sealed SKF Explorer spherical roller bearings are designed to keep lubricant in and contaminants out. The three main benefits of this feature are:

- Greatly increased uptime
- Much lower maintenance
- Minimal grease consumption and environmental impact

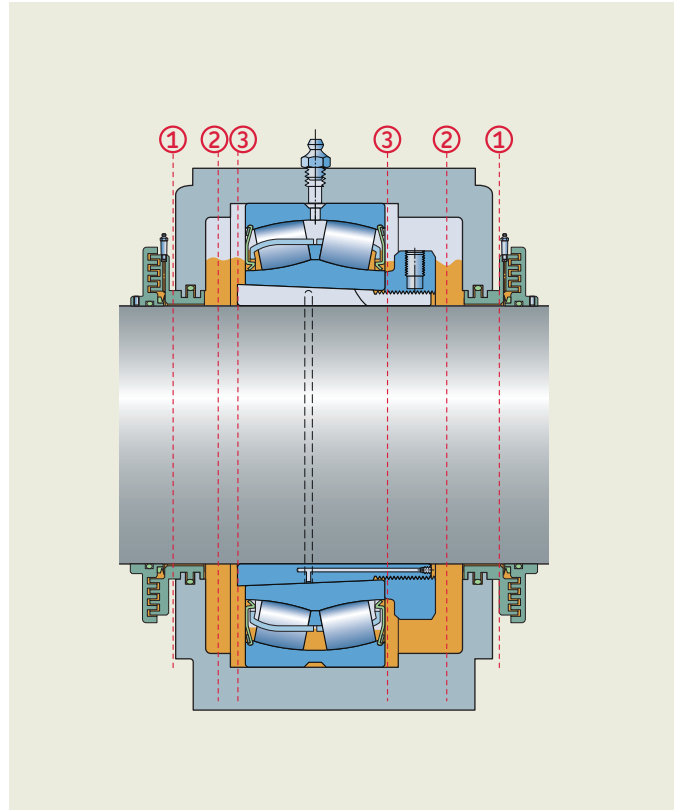

Trouble-free installation and operation

Sealed SKF Explorer spherical roller bearings are pre-lubricated with a high-quality bearing grease and sealed with high-performance contact seals. The seals protect the bearing and lubricant from contaminants that might otherwise cause premature bearing failure – even protecting during installation.

In many applications, sealed SKF Explorer spherical roller bearings can be considered lubricated for the life of the bearing, with no need to purge the pulley bearing to force out contaminants – and no need to purchase, pump and dispose of large quantities of grease.

Take a step further with the SKF Three-barrier solution

For harsh operating environments, the SKF Three-barrier solution is an environmentally friendly, cost-effective solution that extends bearing service life without complicated and expensive sealing arrangements.

- 1 Housing seals** – These standard, cost-effective housing seals are characterized by their ability to prevent the ingress of contaminants.
- 2 Housing grease** – SKF recommends filling the housing preferably with SKF LGGB2 grease to act as a contamination barrier. This biodegradable, environmentally friendly grease is an excellent alternative to filling the housing with bearing grease.
- 3 Integral bearing seals** – These very effective seals keep the high-quality bearing lubricant in and contaminants out of the bearing cavity.

Widest assortment of sealed spherical roller bearings

Sealed SKF spherical roller bearing range

Size mm	Series						Size mm	
	222	223	230	231	232	240		241
05	↔ RS						05	
06	↔ RS						06	
07	↔ RS						07	
08	↔ RS	↔ RS					08	
09	↔ RS	↔ RS					09	
10	↔ RS	↔ RS					10	
11	↔ RS	↔ RS					11	
12	↔ RS	↔ RS					12	
13	↔ RS	↔ RS					13	
14	↔ RS	↔ RS					14	
15	↔ RS	↔ RS					15	
16	↔ RS	↔ RS					16	
17	↔ RS	↔ RS					17	
18	↔ RS	↔ RS					18	
19	↔ RS	↔ RS					19	
20	↔ RS	↔		RS	RS	RS	RS	20
22	↔ RS	↔ RS	RS			RS		22
24	↔ RS		RS					24
26	↔							26
28								28
30								30
32								32
34								34
36								36
38								38
40								40
44								44
48								48
52								52
56								56
60								60
64								64
68								68
72								72
76								76
80								80
84								84
88								88
92								92
96								96
/500								/500
/530								/530
/560								/560
/600								/600
/630								/630
/670								/670
/710								/710
/750								/750
/800								/800
/850								/850
/900								/900
/950								/950
/1 000								/1 000
/1 060								/1 060
/1 120								/1 120
/1 180								/1 180
/1 250								/1 250

↔ = Wider than ISO - Prefix BS2 RS = Wider than ISO - Prefix BS2
 = If you request this size please contact your SKF representative!

skf.com

© SKF is a registered trademark of the SKF Group.

© SKF Group 2019

The contents of this publication are the copyright of the publisher and may not be reproduced (even extracts) unless prior written permission is granted. Every care has been taken to ensure the accuracy of the information contained in this publication but no liability can be accepted for any loss or damage whether direct, indirect or consequential arising out of the use of the information contained herein.

PUB 73/P2 18321 EN · March 2019

Certain image(s) used under license from Shutterstock.com.